

22341

21819

4 Hours / 70 Marks

Seat No.

--	--	--	--	--	--	--	--	--

- Instructions :**
- (1) Answer each next main Question on a new page.
 - (2) Illustrate your answers with neat sketches wherever necessary.
 - (3) Figures to the right indicate full marks.
 - (4) Assume suitable data, if necessary.
 - (5) Use of Non-programmable Electronic Pocket Calculator is permissible.
 - (6) Mobile Phone, Pager and any other Electronic Communication devices are not permissible in Examination Hall.

Marks

1. Attempt any FIVE of the following :

10

- (a) Draw the conventional representation of the following :
 - (i) I-section or rolled section
 - (ii) Long Break in pipe
- (b) Draw the conventional representation for common feature.
 - (i) Radial Ribs
 - (ii) Bearings
- (c) Draw the actual sketch of Counter Bore and Counter Sunk hole.
- (d) Draw the actual sketch and conventional representation :
 - (i) Spiral Spring
 - (ii) Semi-elliptic leaf spring with eyelets.
- (e) Draw the symbols representing the characteristics to be toleranced.
 - (i) Circularity
 - (ii) Cylindricity

[1 of 8]

P.T.O.

- (f) State the meaning of symbols shown in the Fig. No. 1.

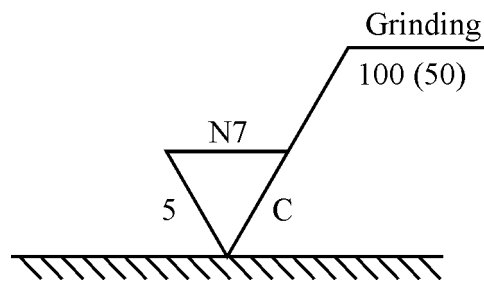

Fig. No. 1

- (g) Refer the Fig. No. 2 and state the meaning of symbol X and Y.

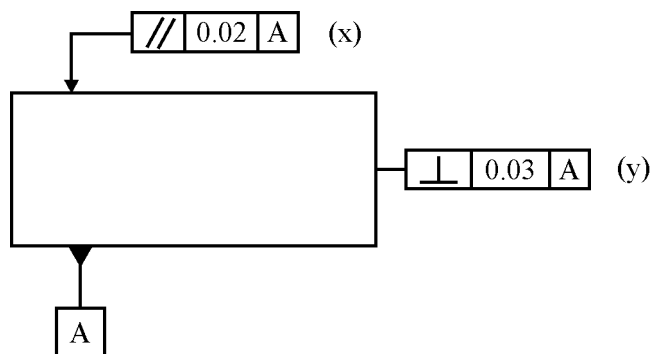

Fig. No. 2

2. Attempt any TWO of the following :

12

- (a) A vertical cylinder of 70 mm diameter is penetrated by another cylinder of 50 mm diameter. The axis of the penetrating cylinder is parallel to both H.P. and V.P. and is 8 mm away from the axis of the vertical cylinder. Draw its projections showing curves of intersection.
- (b) A vertical cylinder of diameter of 70 mm and height 100 mm is completely penetrated by a horizontal square prism of side 50 mm and length 110 mm. The axis of the prism bisects the axis of the cylinder. All the rectangular faces of the prism are equally inclined to H.P. Draw Front View, Top View and Side View showing the curves of intersection.
- (c) A cone with base diameter 80 mm and axis height 75 mm is kept on the H.P. on its base. It is penetrated by a horizontal cylinder of diameter 40 mm with its axis parallel to V.P. and intersecting the axis of the cone at a distance of 25 mm above the base of the cone. Draw the projections solid showing curves of intersection.

3. (A) Attempt any ONE of the following :

(a) Calculate the upper and lower limit of size 50 H7/n6 fit. State the type of fit. Refer Fig. No. 5 for tolerance values.

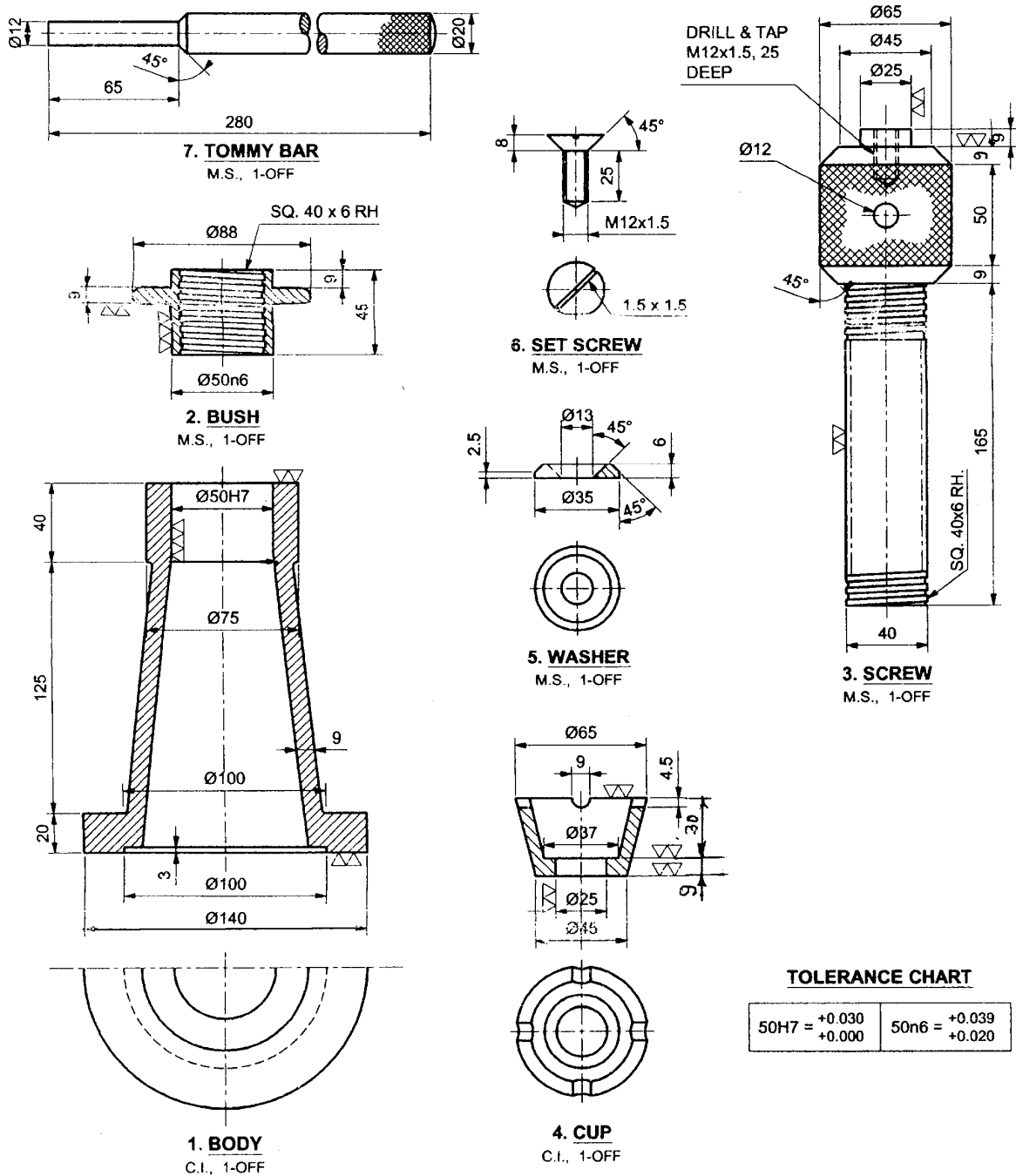

Fig. No. 5

- (b) Define :
- (i) Allowance
 - (ii) Clearance
 - (iii) Interference
 - (iv) Deviation

(B) Attempt any **TWO** of the following :

12

- (i) A cone with base diameter 60 mm and axis length 70 mm rests on its base on H.P. A circular hole of 30 mm diameter is drilled through the cone such that its axis is perpendicular to V.P., parallel to H.P. and 20 mm above the base of cone. Draw the development of the surface showing the effect of the hole if axis of hole is 10 mm to the right of axis of the cone.
- (ii) Draw the development of the lateral surface of the cylinder shown in Fig. No. 3.

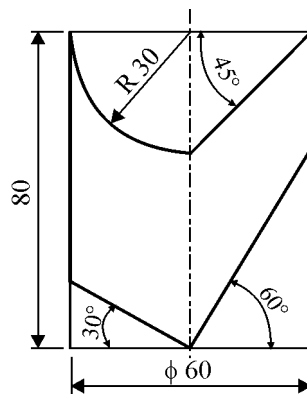
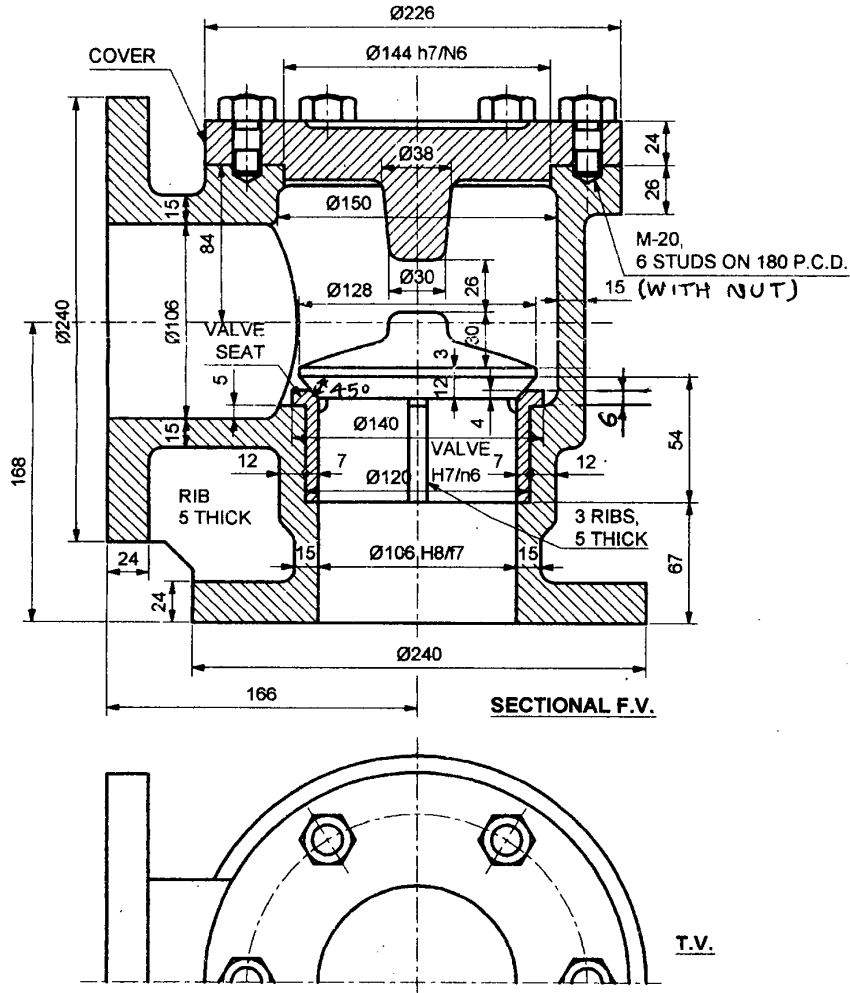

Fig. No. 3

- (iii) A cylinder of base diameter 50 mm and height 75 mm is kept on H.P. A square hole of side 30 mm is drilled through it, the axis of which is perpendicular to V.P., parallel the H.P. and 10 mm to the right of the axis of the cylinder. Axis of the hole is at centre height and all the faces of the hole are equally inclined to H.P. Draw the development of lateral surface of the cylinder in such a way that square hole appears centrally in the development.

4. Attempt the following :

Fig. No. 4 shows the assembly of Non-Return Valve, Attempt any two of the following :



PART LIST

PART NO.	PART NAME	MATERIAL	QTY.
1	BODY	C.I.	1
2	VALVE SEAT	G.M.	1
3	VALVE	G.M.	1
4	COVER	C.I.	1
5	STUD WITH NUT	M.S.	6

Fig. No. 4

- (1) Draw the Sectional Front View and Top View of body.
- (2) Draw the Front View and Top View of Valve.
- (3) Draw the Sectional Front View and Top View of Cover.

5. Attempt any ONE of the following :

(a) Fig. No. 5 shows the details of screw jack. Draw the

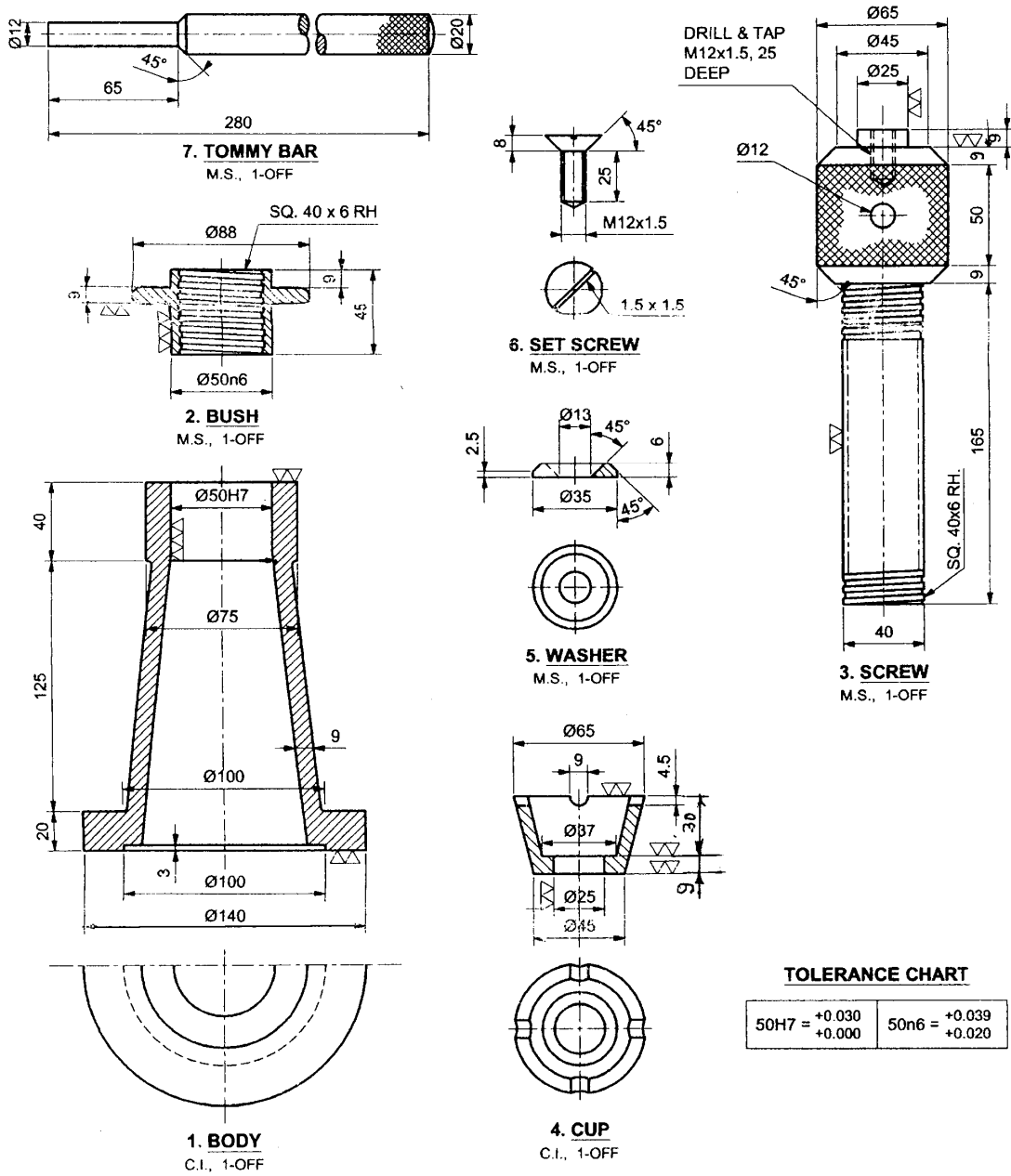

Fig. No. 5

- (i) Sectional Front View
- (ii) Top view
- (iii) Part List and Dimensions

(b) Fig. No. 6 shows the details of Oldham's coupling. Draw the following views of the assembly :

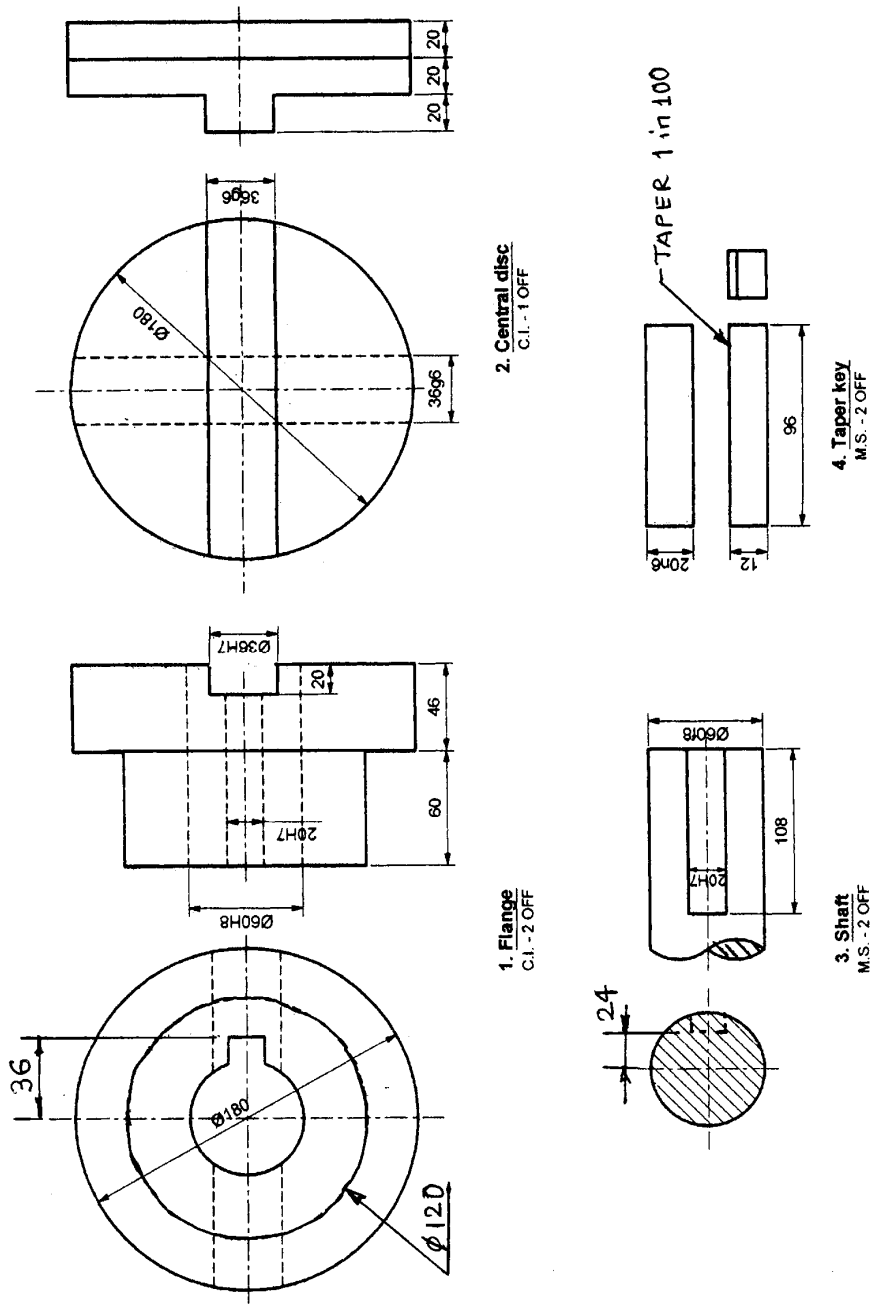

Fig. No. 6

- (i) Sectional Front View
- (ii) Left hand Side View

22341

[8 of 8]

- (iii) Give overall dimensions. Indicate the parts on assembly. Prepare bill of material. Indicate assembly fits on the drawing. The axes of shafts are parallel to each other and 24 mm apart.
-